



CM-1.1 and CM-2.1 Electric Motor Control Modules for A-dec 300 and A-dec 500 Systems INSTALLATION GUIDE



DANGER Failure to turn off the power before you begin this procedure can lead to electrical shock.



WARNING Failure to turn off the power before you begin this procedure can lead to product damage and result in serious injury or death.



Electric components on the circuit board are static sensitive and require handling precautions.



CAUTION When removing or replacing covers, take care not to damage any wiring. Verify that the covers are secure after replacing them.



A-dec 300



A-dec 500

Figure 1. The CM-2.1 Control Module with the A-dec EA-30 and/or the EA-52LED Electric Motor

Recommended Tools

- Phillips head screwdriver
- Hex key set



Installation

Go to the section for your type of system:

- “A-dec 300” below
- “A-dec 500” on page 9

A-dec 300

Remove the Covers

1. Turn the master on/off toggle to the off position.
2. Remove the delivery system covers.
 - (1) Use a 7/64" hex key to remove the back cover screws.
 - (2) Lift the back cover off.
 - (3) Use a 7/64" hex key to loosen the front cover screws.
 - Traditional: Remove the front cover.
 - Continental: Lift up the front cover.
3. If necessary, install the deluxe touchpad and Continental® whip assembly. Follow the instructions provided in the kits that came with those components.

Figure 2. Remove the Delivery System Covers

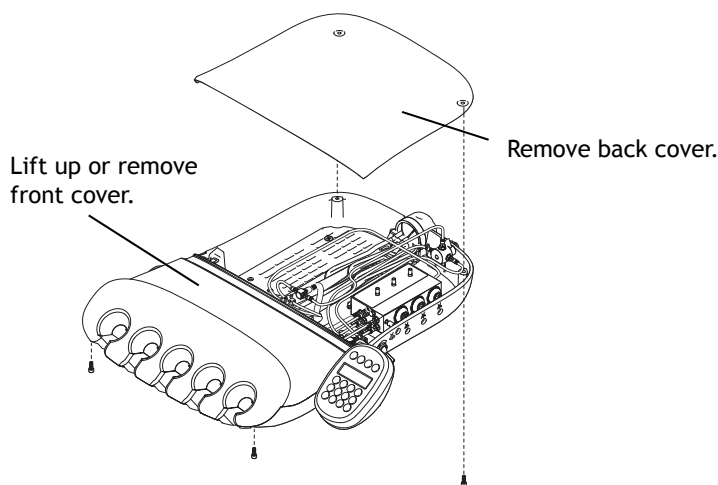

Install the Handpiece Tubing on a Traditional Control Head

1. Route the tubing up through the bottom of the control head platform and into the control head.
2. Install a cable tie to serve as a strain relief, allowing enough slack to make adjustments in the tubing position.
3. Adjust the tubing length so it drapes evenly with the syringe tubing.
4. Tighten the cable tie to secure the tubing in place.

Figure 3. Install the Tubing in a Traditional System

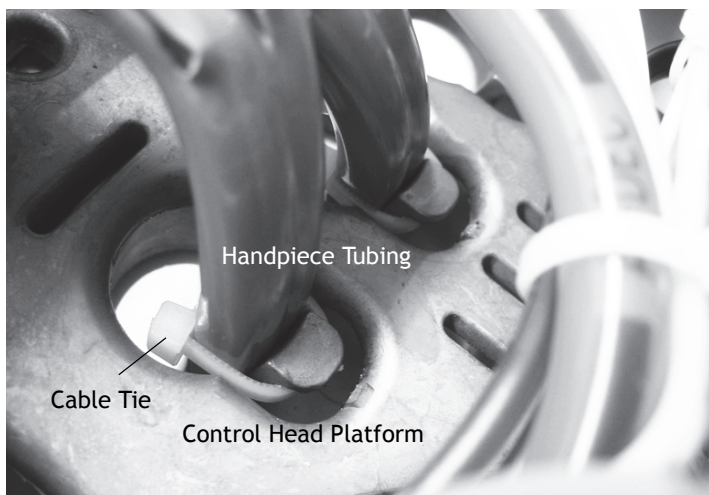

NOTE Do not overtighten the cable ties around the handpiece tubing as this can restrict air and water flow.

Install the Handpiece Tubing on a Continental Control Head

1. Pull the drip shield down from the front cover to access the tubing.
2. Remove the whip hook. Insert the handpiece tubing into the whip tube and route it into the control head.
3. Squeeze the handpiece tubing into the whip hook. Adjust the length until it drapes evenly with the syringe tubing.
4. Install the black cable bushing and the cable tie.
5. Pull the tubing until the cable tie touches the cable bushing.
6. Reinstall the whip hook.
7. Use a cable tie to secure the tubing to the drip shield channel. Make sure to leave a service loop so the tubing does not kink. Trim the cable tie when finished.
8. Reinstall the drip shield on the front cover.



NOTE Do not overtighten the cable ties around the handpiece tubing as this can restrict air and water flow.

Figure 4. Pull the Drip Shield Down

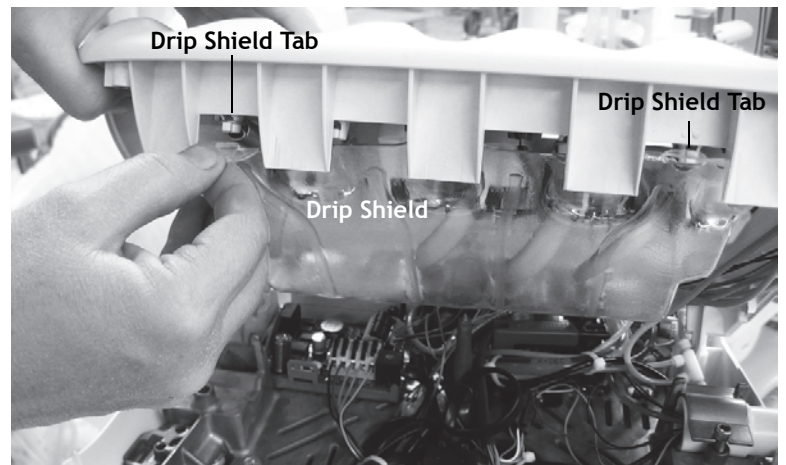

Figure 5. Install the Tubing, Bushing, and Cable Tie

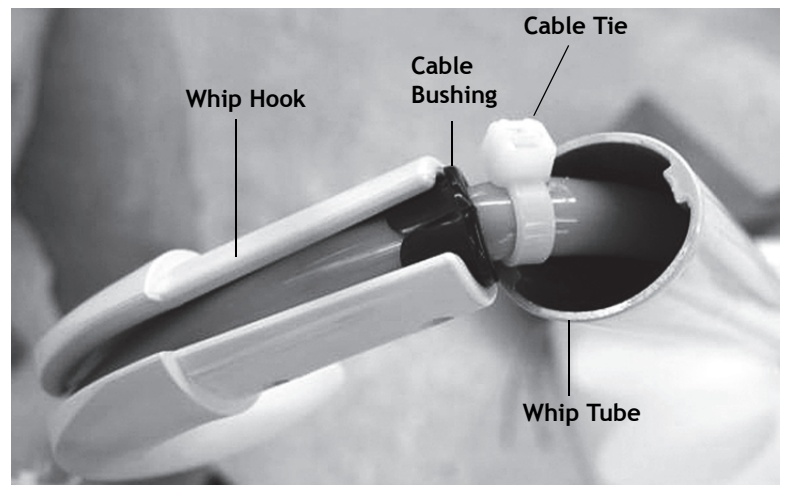

Figure 6. Secure the Tubing to Continental Drip Shield

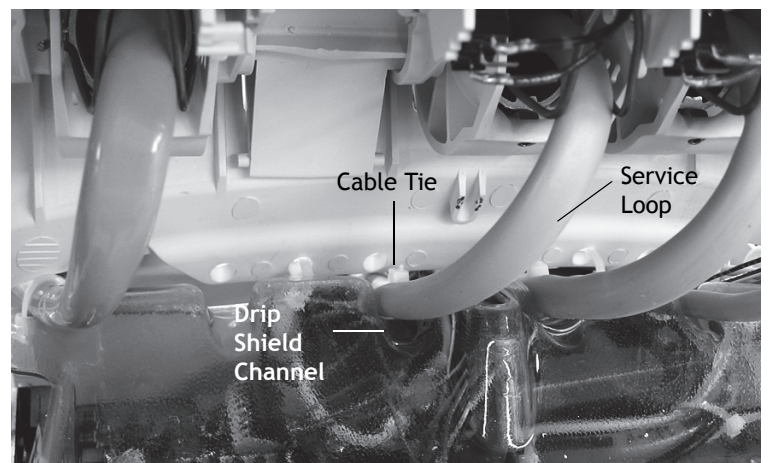
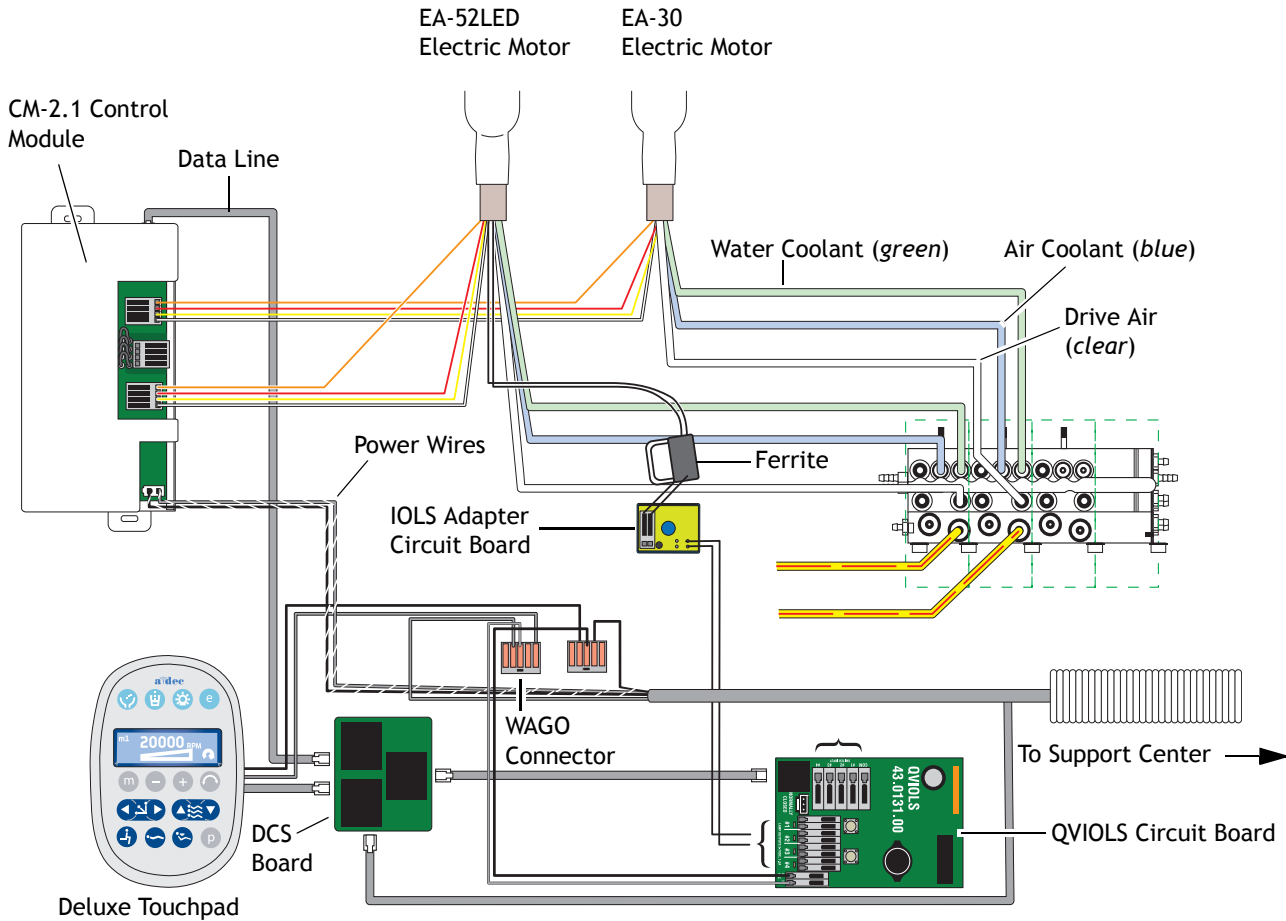

Figure 7. A-dec 300 CM-1.1/2.1 E Flow Diagram



Connect the Handpiece Tubing to the Control Block

1. Open the slide lock and connect the handpiece tubing to the appropriate position on the control block.
 - Blue tubing to air coolant port.
 - Green tubing to water coolant port.
 - Transparent tubing to the drive air port.



NOTE Do not trim the handpiece tubing. Carefully coil the tubing in the control head for future use and servicing.

Figure 8. Connect the Tubing to the Control Block

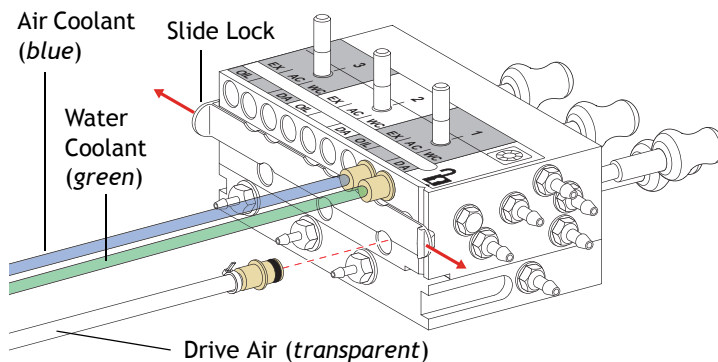

2. Close the slide lock.

Install the Control Module and Connect the Wires

1. Plug in the data line.

Figure 9. Plug in the Data Line



2. Position the control module in the rear of the control head.

Figure 10. Position the Control Module - CM 2.1 Control Module Shown

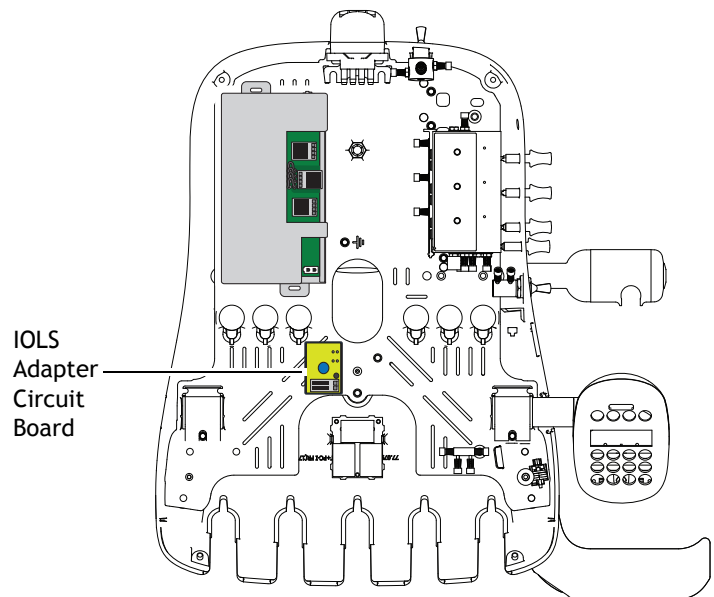

- Use two self-tapping screws to secure the control module to the control head.

Figure 11. Secure the Control Module



- Plug in the A/C power.

Figure 12. Plug in the A/C Power

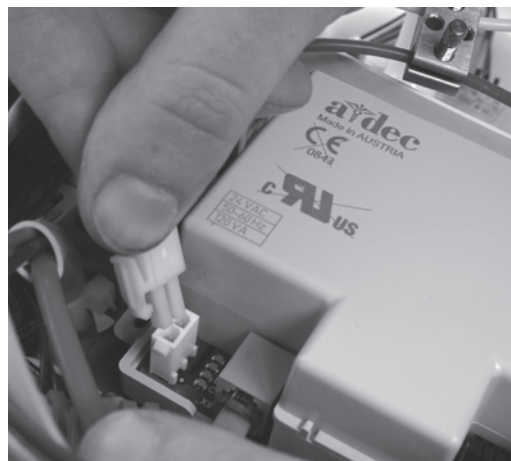

- Insert the motor wires into their positions on the control module:

Connect This Wire	To Terminal
White	wt
Yellow	ye
Red	rd
Orange	or



NOTE For a single motor on the CM 2.1 control module, use the Motor 1 connector. If installing two motors, use the Motor 1 connector for the first motor and the Motor 2 connector for the second motor.

Figure 13. Connect the Handpiece Motor Wires

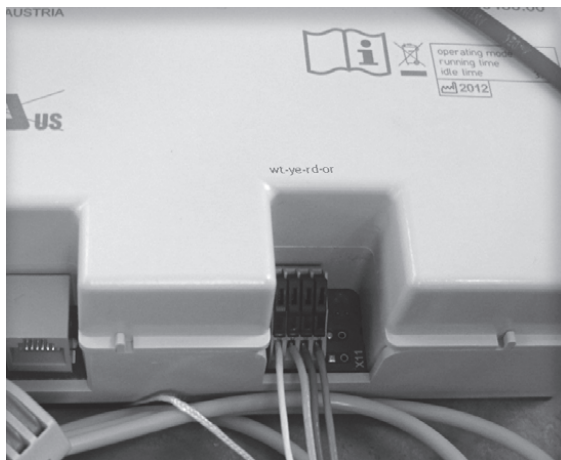

Install the IOLS Adapter LED Circuit Board for the EA-52LED

1. Use the Phillips head screw to install the IOLS adapter LED circuit board in the control head.
2. For each EA-52LED handpiece position, connect the black wires from the adapter board to the corresponding fiber optic output position on the quad volt IOLS circuit board.
3. Insert the handpiece wires into the ferrite and loop them around the ferrite one time.
4. Position the ferrite about 1" from the end of the wires.
5. Insert the handpiece wires into the connector on the IOLS adapter board. Connect the violet wire to the + side and the black wire to the - side.

Figure 14. Install the IOLS Adapter Handpiece LED Circuit Board

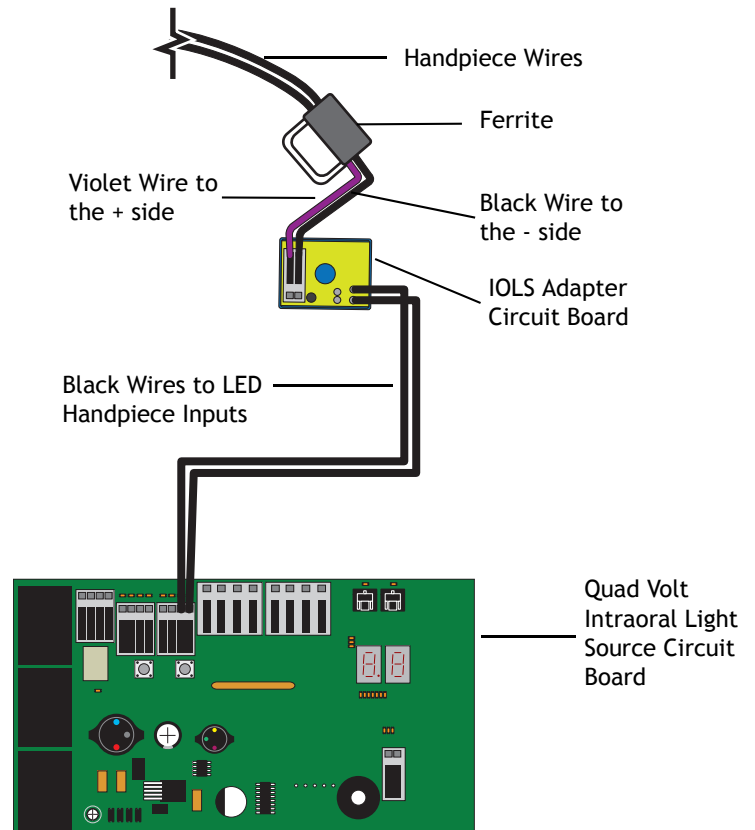

Set the Lamp Voltage (EA-52LED only)

1. Turn on the master toggle.
2. Access the QVIOLS circuit board.
3. Use a volt meter to measure the voltage at the terminal strip. Set the meter to read VDC.
4. Activate the handpiece and ensure the lamp illuminates.
5. Adjust the voltage by pressing the Increase and Decrease buttons on the circuit board.
6. To achieve 3.2 V at the lamp, set the voltage at the terminal strip to:
 - 3.47 VDC for 61" handpiece tubing
 - 3.57 VDC for 82" handpiece tubing

Figure 15. Adjust the EA-52LED Lamp Voltage With the QVIOLS

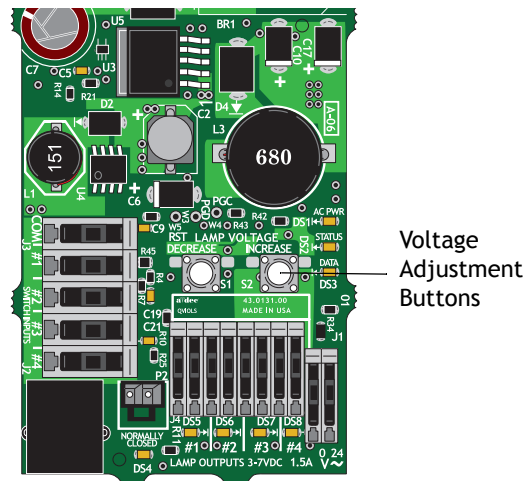

Program the A-dec 300 Deluxe Touchpad

1. Turn on the system power.
2. To enter **System Setup**, press the **m** and **e** buttons at the same time for three seconds and then press **▶**.



NOTE Use the minus **-** or plus **+** buttons to change menu options. Press **▶** to make a selection.

3. In the **System Setup** menu, select **Handpieces**.
4. Select **Holder Setup**.
5. On Traditional systems, lift the motor. On Continental systems, pull the whip forward.
6. Select **Electric**.
7. Select **Motor Number 1** (position 1 on the control module).
8. Select the motor type.
9. Set the installed cable length and save the settings. You should hear three beeps. Move the whip back or return the motor to its holder.
10. For systems with two electric motors, repeat steps 3 through 9 and select motor number 2.
11. Press **◀** until the A-dec logo appears, indicating that you are no longer in the **System Setup** menu.
12. Continue with "Adjust the Drive Air Pressure" on page 16.

Figure 16. Select the Electric Motor

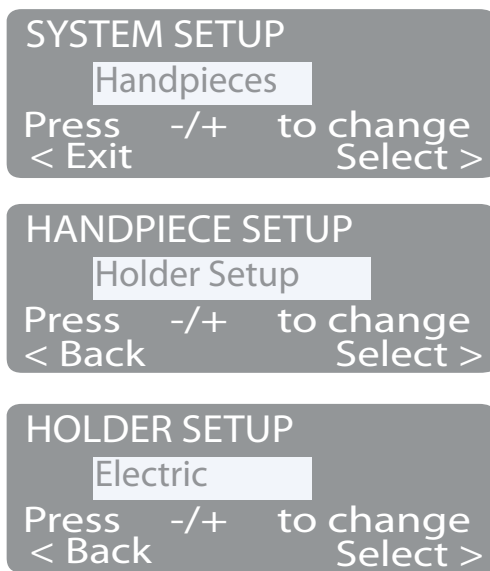
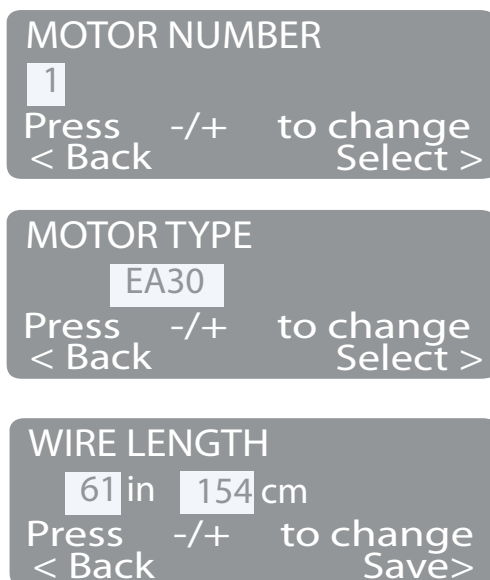

Figure 17. Select Motor Number, Type, Cable Length



A-dec 500

Remove the Covers

1. Turn the master on/off toggle to the off position.
2. Lift the control head cover up and back.
3. Remove the two hex screws and:
 - For Traditional: Pull forward and up to remove the control head top cover.
 - For Continental: Pivot the cover forward, assuring the lanyard is connected to the cover and control head to prevent strain in the cover hinges.
4. If necessary, install the deluxe touchpad and Continental® whip assembly. Follow the instructions provided in the kits that came with those components.

Figure 18. Traditional Control Head Covers

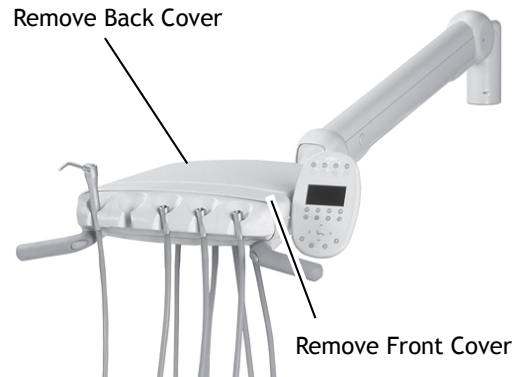

Figure 19. Continental Control Head Covers

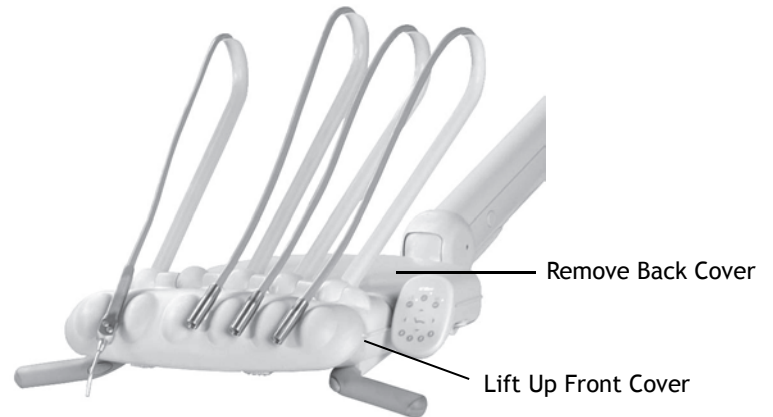
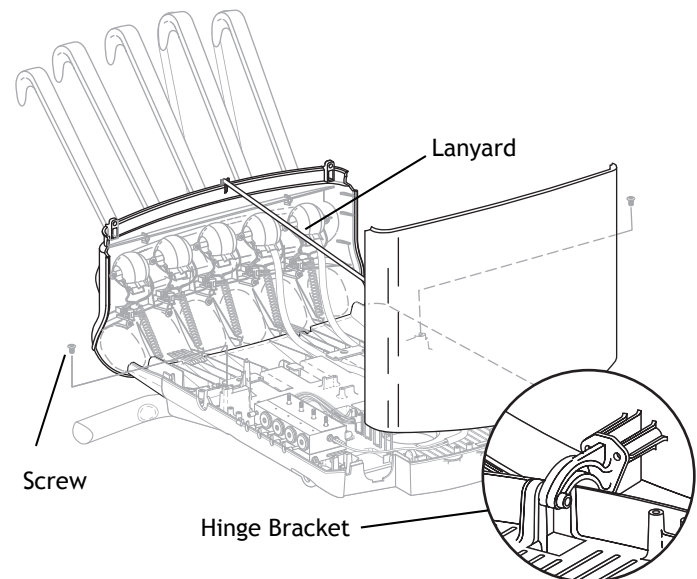

Figure 20. Pinch Hinge Bracket



Install the Handpiece Tubing on a Traditional Control Head

1. Remove the tubing guide from the underside of the control head.
2. Twist and remove the plug from the guide.
3. Insert the handpiece tubing into the guide.
4. Replace the guide in the control head.
5. Adjust the length of the tubing so it drapes evenly with the syringe tubing.
6. Cable tie the tubing to the control head structural platform. See Figure 22.
7. Use the screw from the kit to secure the strain relief string to the structural platform.
8. Ensure the handpiece actuator lever on the holder is released.

Figure 21. Traditional Control Head Tubing Routing

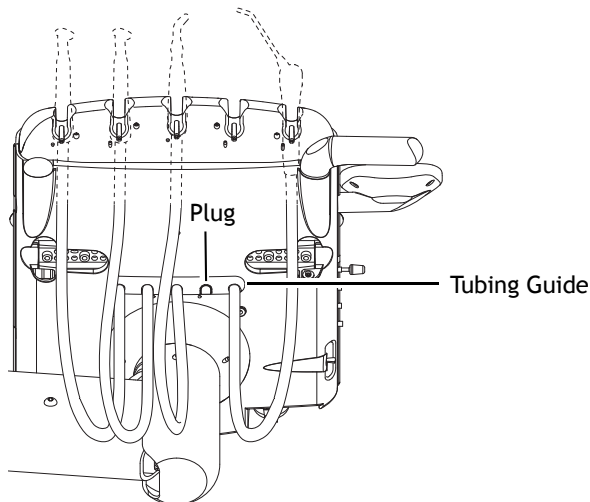

Figure 22. Secure the Tubing to the Structural Platform

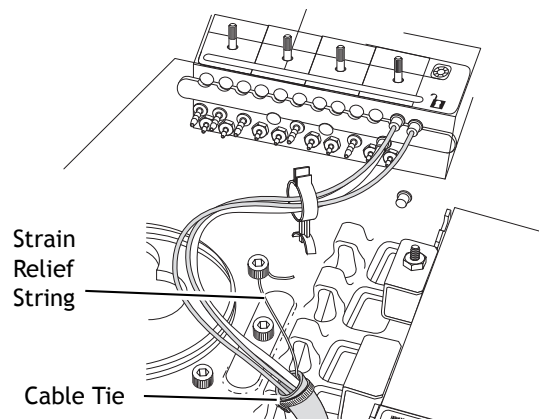

Figure 23. Continental Control Head Tubing Routing

Install the Handpiece Tubing on a Continental Control Head

1. Remove the spring from the bail.
2. Use a 7/16" hex key to remove one screw and loosen the other on each side of the whip pivot.
3. Remove the whip cover.
4. Insert the handpiece tubing into the whip.
5. Route the handpiece tubing through the pivot toward the control head.
6. Install the whip back, starting at the pivot end of the whip.
7. Route the tubing to the slot right of the whip and then under the control head circuit board.
8. Cable tie the tubing to the control head structural platform.
9. Adjust the length of the tubing so it drapes evenly with the syringe tubing.
10. Cable tie the tubing at the base of the whip.
11. Secure the strain relief string to the whip assembly.
12. Ensure the handpiece actuator lever on the holder is released.

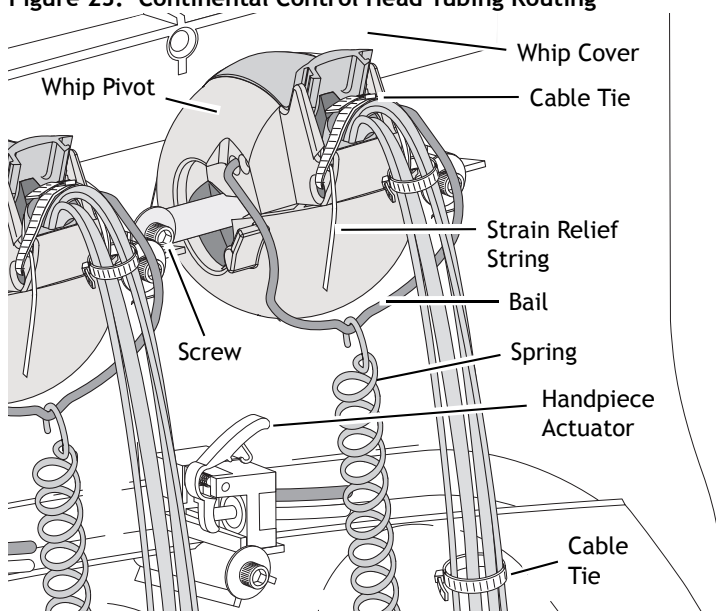
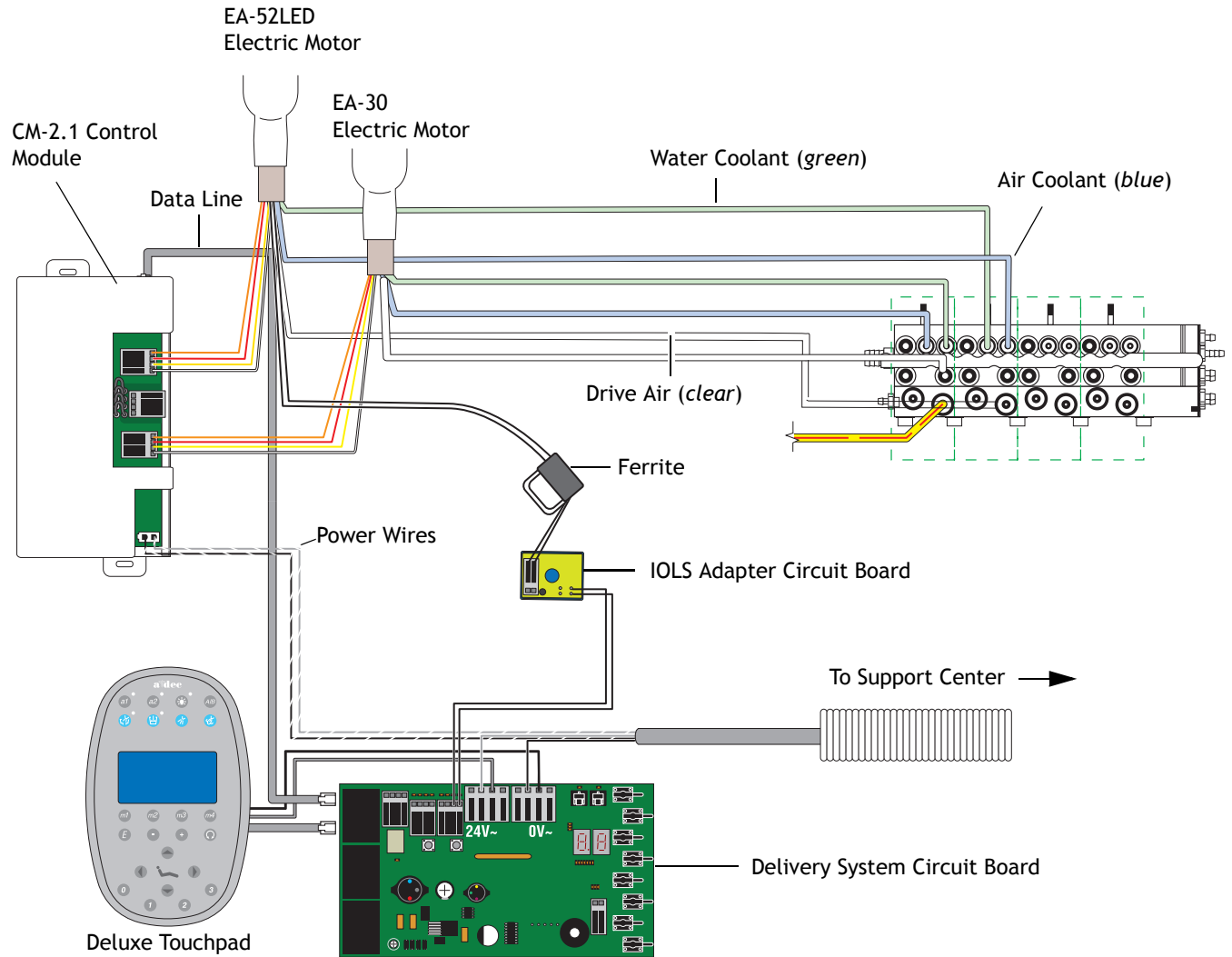

Figure 24. A-dec 500 CM-2.1 Flow Diagram



Connect the Handpiece Tubing to the Control Block

1. Open the slide lock and connect the handpiece tubing to the appropriate position on the control block.
 - Blue tubing to air coolant port.
 - Green tubing to water coolant port.
 - Clear tubing to the drive air port.



NOTE Do not trim the handpiece tubing. Carefully coil the tubing in the control head for future use and servicing.

2. Close the slide lock.

Figure 25. Control Block

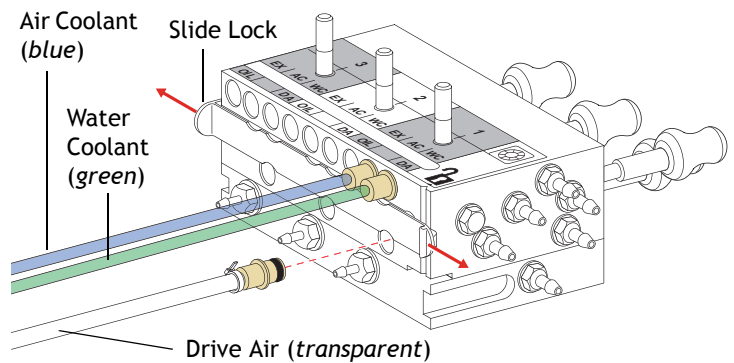

Install the Control Module and Connect the Wires

1. Plug in the data line.

Figure 26. Plug in the Data Line



2. Position the control module in the rear of the control head.

Figure 27. Mount the Control Module - CM 2.1 Control Module Shown

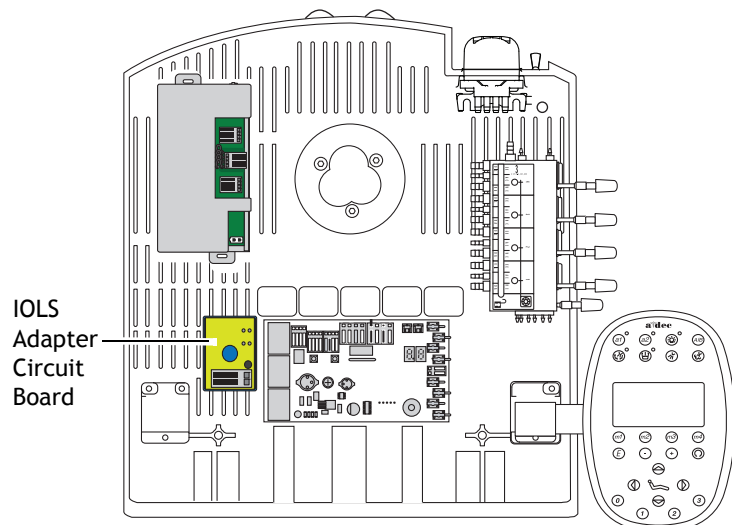

3. Use two self tapping screws to mount the control module to the control head.

Figure 28. Secure the Control Module



4. Plug in the A/C power.

Figure 29. Plug in the A/C Power

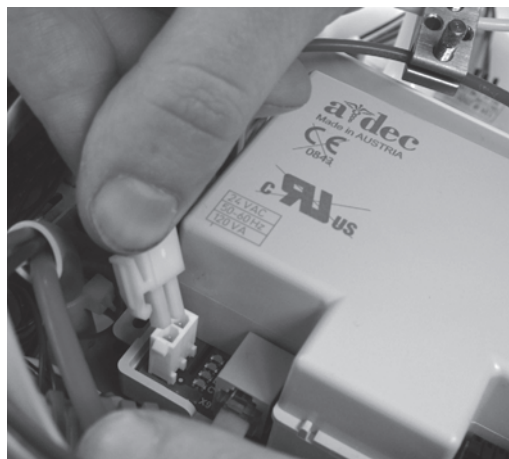

5. Insert the motor wires into their positions on the control module:

Connect This Wire	To Terminal
White	wt
Yellow	ye
Red	rd
Orange	or



NOTE For a single motor on the CM 2.1 control module, use the Motor 1 connector. If installing two motors, use the Motor 1 connector for the first motor and the Motor 2 connector for the second motor.

Figure 30. Connect the Handpiece Motor Wires

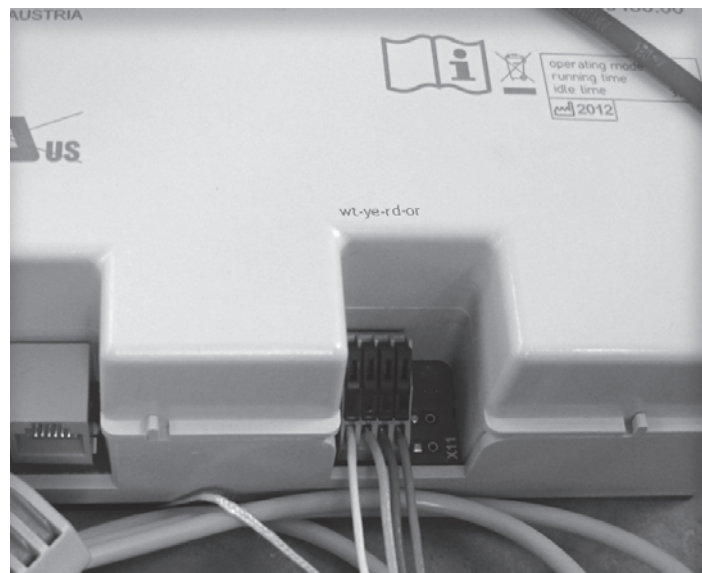

Install the IOLS Adapter LED Circuit Board for the EA-52LED

1. Use the Phillips head screw to install the IOLS adapter LED circuit board in the control head.
2. For each EA-52LED handpiece position, connect the black wires from the adapter board to the corresponding fiber optic output position on the control head circuit board.
3. Insert the handpiece wires into the ferrite and loop them around the ferrite one time.
4. Position the ferrite about 1" from the end of the wires.
5. Insert the handpiece wires into the connector on the IOLS adapter board. Connect the violet wire to the + side and the black wire to the - side.

Figure 31. Install the IOLS Adapter Handpiece LED Circuit Board

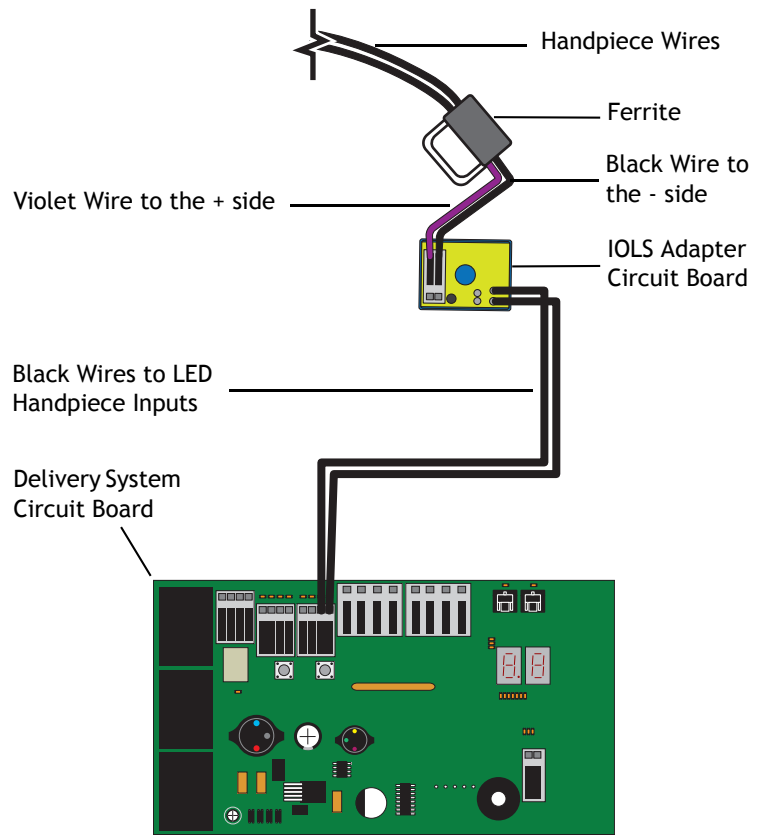

Adjust the Fiber-Optic Voltage

1. Turn on the master toggle.
2. Access the delivery system circuit board.
3. Use a volt meter to measure the voltage at the terminal strip. Set the meter to read VDC.
4. Activate the handpiece and ensure the lamp illuminates.
5. Adjust the voltage by pressing the Increase and Decrease buttons on the circuit board.
6. To achieve 3.2 V at the lamp, set the voltage at the terminal strip to:
 - 3.47 VDC for 61" handpiece tubing
 - 3.57 VDC for 82" handpiece tubing

Figure 32. Fiber-Optic Adjustment

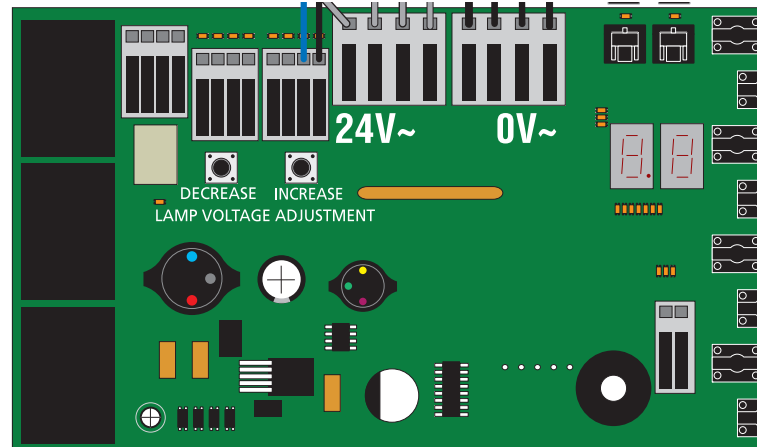

Program the A-dec 500 Deluxe Touchpad

1. Turn on the system power.
2. From the deluxe touchpad main screen, press and hold the A/B (A/B) and Program (P) or (P) buttons at the same time for three seconds; then press ▶ to begin.
3. In the **System Setup** menu, select **Handpieces**.
4. Select **Holder Setup**.
5. On Traditional systems, lift the motor. On Continental Systems, pull the whip forward.
6. Select **Electric**.
7. Select **Motor Number 1** (position 1 on the control module).
8. Select the motor type.
9. Set the installed cable length and save the settings. You should hear three beeps. Move the whip back or return the motor to its holder.
10. For systems with two electric motors, repeat steps 3 through 9 and select motor number 2.
11. Press ◀ until you see the A-dec logo.

Figure 33. Select the Electric Motor

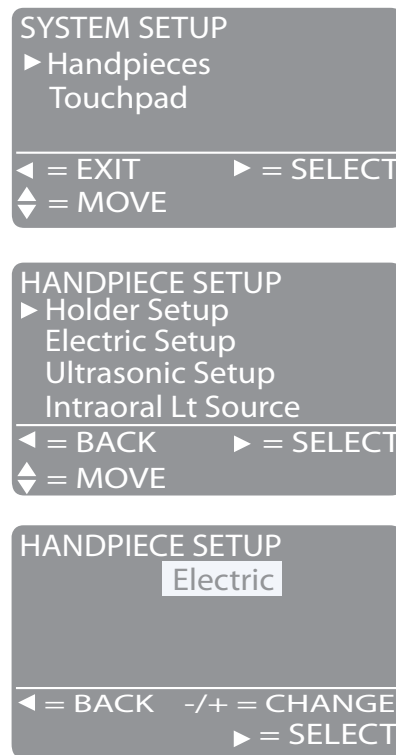
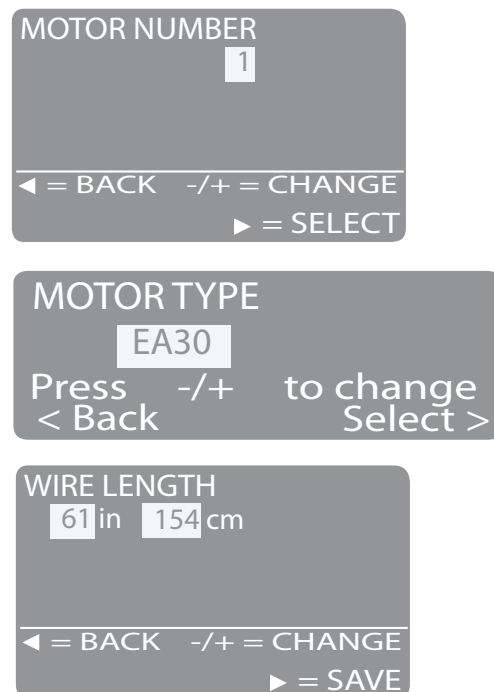



Figure 34. Select Motor Number, Type, Cable Length



Adjust the Drive Air Pressure

1. Fully depress the foot control.
2. Adjust the drive air flow (the controls are on the top of the control block) to the handpiece manufacturer's specifications.



NOTE Use a handpiece pressure gauge to accurately adjust the drive air for the handpiece tubings. In addition, there is a digital gauge in the control head that reads drive air pressure at the control block or you display the pressure on the deluxe touchpad by pressing the plus  and minus  buttons at the same time.

Further Help

For more information on installing related components on an A-dec 300 system, see the *A-dec 300 Service Guide* (p/n 85.0818.00).

Regulatory Information

Regulatory information is provided with A-dec equipment as mandated by agency requirements. This information is delivered in the equipment's *Instructions for Use* or the separate *Regulatory Information and Specifications* document. If you need this information, please go to the Document Library at www.a-dec.com.

Test the Handpiece

1. Select the handpiece.
2. Verify that the motor functions with all of the motor option settings on the deluxe touchpad. These include:
 - Motor speed
 - Motor direction
3. Replace the covers.



CAUTION When removing or replacing covers, take care not to damage any wiring. Verify that the covers are secure after replacing them.

A-dec Headquarters

2601 Crestview Drive
Newberg, OR 97132 USA
Tel: 1.800.547.1883 Within USA/Canada
Tel: 1.503.538.7478 Outside USA/Canada
Fax: 1.503.538.0276
www.a-dec.com / www.a-dec.biz

A-dec Inc. makes no warranty of any kind with regard to the content in this document including, but not limited to, the implied warranties of merchantability and fitness for a particular purpose.

