

Owner's Guide



DECADE[®] ***1011 CHAIR***

A-dec warrants its products against defects in material or workmanship for one year from time of delivery (except for handpieces which have a warranty period of six months). A-dec's sole obligation under the warranty is to provide parts for the repair, or at its option, to provide the replacement product (excluding labor). The buyer shall have no other remedy. (All special, incidental, and coincidental damages are excluded.) Written notice of breach of warranty must be given to A-dec within the warranty period. The warranty does not cover damage resulting from improper installation or maintenance, accident or misuse. The warranty does not cover damage resulting from the use of cleaning, disinfecting or sterilization chemicals and processes. The warranty also does not cover light bulbs. Failure to follow instructions provided in A-dec's Operation and Maintenance Instructions (Owner's Guide) may void the warranty.

NO OTHER WARRANTIES AS TO
MERCHANTABILITY OR OTHERWISE ARE MADE



All product names used in this document are trademarks or registered trademarks of their respective holders.

Decade 1011 Chair



Decade 1011 Chair

CONTENTS

Operation

About Your Decade 1011 Chair	2
8-Function Footswitch	3
Touch Pad (optional)	3
Folding Armrest	9
Swivel Brake	9
Double Articulating Headrest	10
Positioning For Wheel Chair	11
Headrest Drift Adjustment	12
Left/Right Conversion	13
Optional Duplex Outlet	15
Care Instructions	15
<i>(Refer also to your Equipment Asepsis Owner's Guide, A-dec Publication No. 85-0696-00.)</i>	

Maintenance

Upholstery Replacement	16
Backrest Upholstery	16
Seat/Toeboard Upholstery	17
Armrest Upholstery	18
Double Articulating Headrest Upholstery	19
Service Information	20

OPERATION

About Your Decade 1011 Chair

Your Decade 1011 Dental Chair is an electronically controlled, hydraulically powered dental chair that uses one of the quietest hydraulic pumps available. The pump powers two hydraulic cylinders: one for base lift and one for chair back and toeboard tilt (see Figure 1).

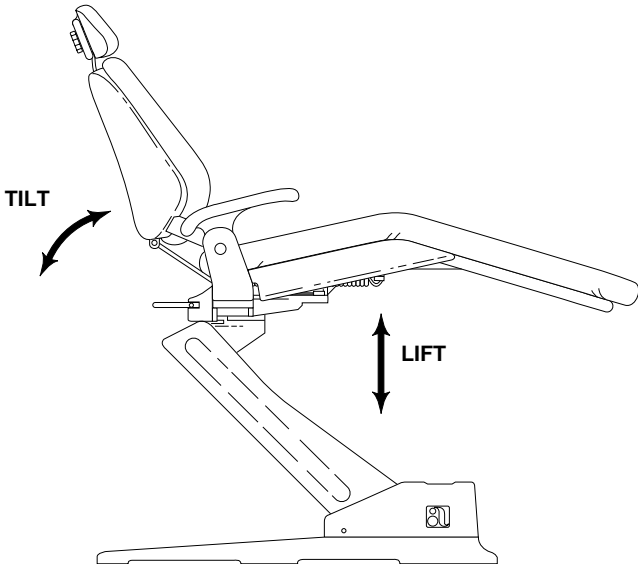

Figure 1. Lift and Tilt Operations

The low voltage microcomputer-based electronics module in your chair is capable of storing your preferred operating and patient entry/exit positions. Chair functions are controlled by the 8-Function Footswitch or optional touch pad (see Figure 2 or 2a on page 3).

8-Function Footswitch

The 8-Function Footswitch (see Figure 2) or the optional Chair Touch Pad (see Figure 2a) gives you both manual and programmed control of chair positioning. The left-hand rocker button on the footswitch manually controls chair back/toeboard tilt and chair lift. The right-hand rocker button is for Auto Return and programmed chair positions.

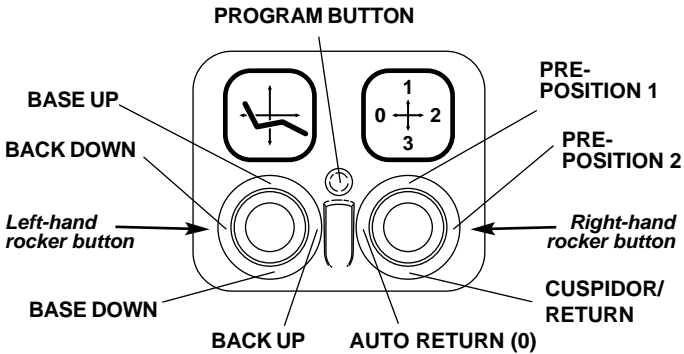

Figure 2. 8-Function Footswitch

Touch Pad (optional)

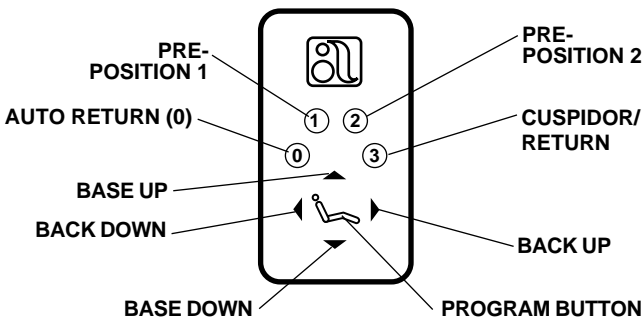

Figure 2a. Chair Touch Pad

Manual Control

The ***Base Up/Down (lift)*** function controls the chair's lift, or vertical movement. To raise the chair, move the left-hand rocker button on the footswitch to the 12 o'clock position or press the top arrowhead on the touch pad. To lower the chair, move the rocker button to the 6 o'clock position or press the bottom arrowhead button on the touch pad. Hold the rocker or button until the chair reaches the desired height, then release it.

The ***Back Up/Down (tilt)*** function controls the chair back/toeboard tilt. To raise the chair back, move the left-hand rocker button on the footswitch to the 3 o'clock position or press the right arrowhead button on the touch pad. To lower the chair back, move the rocker button to the 9 o'clock position or press the top arrowhead button on the touch pad. Hold the rocker or button until the chair back reaches the desired position, then release it.

Program Button

The Program Button (located in the middle of the footswitch, or in the middle of the arrows on the touch pad) is used to save the settings for Auto Return (0), Pre-Positions (1 and 2), and Cuspidor/Return (3).

Pre-Positions 1 and 2

Note

When the right-rocker button is moved to a Pre-Position (or when 1 or 2 are pressed on the touch pad), the chair base and back go to the preset position.

To stop the chair at any point, momentarily move any button on the footswitch (or press any button on the touch pad).

To send the chair to a preset operating position (called Pre-Position), momentarily move the right-hand rocker button to either 1 or 2 (or press 1 or 2 on the touch pad). Pre-Positions 1 and 2 are programmed at the factory to move the chair to the same position.

To change a Pre-Position locate the program button on the footswitch or touch pad (see *Figures 2 or 2a on page 3*).

1. Using the left-hand rocker button on the footswitch (or the arrow buttons on the touch pad), set the chair to the operating position that you prefer.
2. Press and release the program button. An audible tone will be emitted. Then, **within four seconds**, move the right-hand rocker button to the Pre-Position setting 1 or 2 (or press 1 or 2 on the touch pad) to store that position. You will hear an audible tone confirming that the Pre-Position function has been reprogrammed.
3. Check the programmed Pre-Position by manually moving the chair to another position. Then move the right-hand rocker to the Pre-Position (or press 1 or 2 on the touch pad) programmed in Step 2. The chair should move automatically to the position set in Step 1.

Optional Program Functions

Position 3 (6 o'clock) on the footswitch right-hand rocker button and button 3 on the touch pad are factory set in the **Cuspidor/Return** mode. In this mode, the chair back will rise to a pre-programmed upright position providing the patient access to the cuspidor. Momentarily selecting position 3 or pressing button 3 a second time lowers the chair back to its previous operating position.

Position 3 or button 3 also allows for two optional functions: **Pre-Position** or **Last Position**. These functions are determined by two switches located on the chair controller board under the pump housing cover (see *Figure 3 on Page 7*).

Using position 3 or button 3 in the **Pre-Position** mode allows you to place the chair in a desired position and recall it by selecting position 3 or pressing button 3.

Last Position is a non-programmable function that simply moves the chair base and back to the previous position. Using this feature allows the chair to be moved back and forth between two positions by momentarily selecting position 3 or pressing button 3.

To change the function of position 3 or button 3, use the following procedure:

1. Unplug the chair.

WARNING

Hazardous AC voltages are present on the circuit board until you unplug the chair. Failure to unplug the chair can result in serious injury.

2. Using a 5/32-inch hex wrench, remove the pump cover.
3. Using a 5/64-inch hex wrench, remove the circuit board cover.

4. Locate the red two-position switch labeled S2 on the circuit board (see Figure 3).
5. Using a ball-point pen or small screwdriver, set the two switches to the desired function.

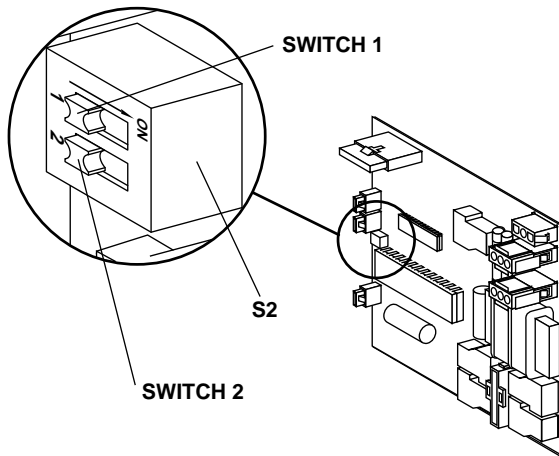

Figure 3. Switch Locations

Function	Switch 1	Switch 2
Cuspidor/Return (factory setting)	OFF	OFF
Last Position	ON	OFF
Pre-Position	OFF	ON

6. Replace the covers and plug in the chair.
7. If you have selected **Pre-Position**, move the back to the desired position. Press and release the program button. An audible tone will be emitted. Then, **within four seconds**, move the right-rocker button to position 3. You will hear an audible tone confirming that the chair has been reprogrammed.
8. Test the chair for proper operation of the programmed position 3 function.

Auto Return (0)

To send the chair to a preset entry/exit position, or Auto Return, momentarily move the right-hand rocker button to the 9 o'clock (0) position, or press the "0" button on the touch pad (see *Figure 2 or 2a on page 3*).

Note

When moved, Auto Return (0) will cause the chair base and back to go to the preset entry/exit position.

To stop the chair at any point, momentarily move any button on the footswitch or touch pad.

If you want to change the preset entry/exit position, first locate the program button on the footswitch or touch pad (see *Figure 2 on page 3*).

1. Using the left-hand rocker button on the footswitch (arrows on the touch pad), set the chair to the desired patient entry/exit position.
2. Press and release the program button. An audible tone will be emitted. Then, **within four seconds**, press the Auto Return (0) button on the footswitch or touch pad. You will hear an audible tone confirming that the chair has been reprogrammed. This stores your preferred patient entry/exit position in the Auto Return (0) function.
3. Check the Auto Return (0) function by using the manual controls to move the chair to another position. Move the right-hand rocker button to the Auto Return (0) position or press "0" on the touch pad. The chair should move automatically to the position you set in Step 1.

Folding Armrest

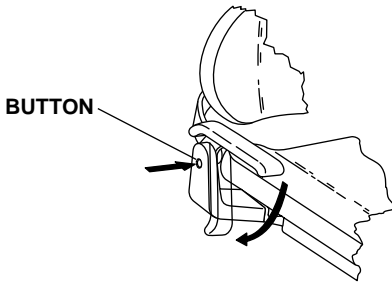

Figure 4. Folding Armrest

The armrests fold down and out of the way to facilitate patient entry/exit. When lifted, the armrests lock securely in place for patient comfort during procedures. To lower an armrest, press the button on the outboard side of the arm. Lock the armrest by lifting it until it locks in place.

Swivel Brake

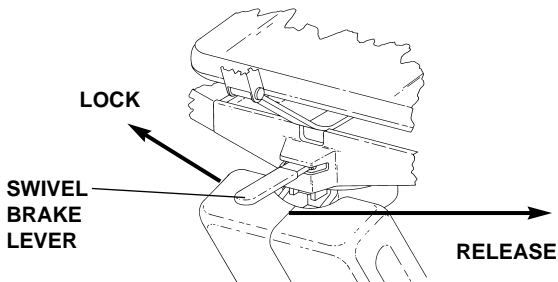

Figure 5. Swivel Brake

When engaged, the chair swivel brake restricts rotation of the chair. With the brake released, you can rotate the chair to any position within approximately 30° either side of center. To release the swivel brake, push the brake lever to the right. To engage the swivel brake, push the brake lever to the left.

Double Articulating

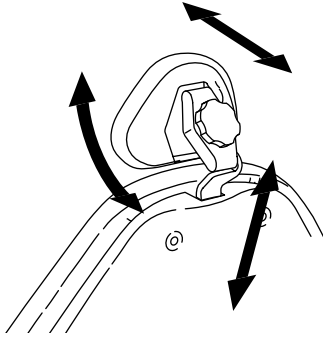

Figure 6. Double Articulating Headrest

The Double Articulating Headrest offers the widest range of headrest positions possible. A convenient locking knob allows you to easily accommodate most patients and procedures.

To position the headrest, release the locking knob by turning the knob out (counterclockwise), then adjust the headrest as necessary to fit the head and neck. Lock the headrest in the desired position by turning the knob in (clockwise).

To move the headrest higher or lower, simply pull up or push down on the headrest until it is at the desired height. (Refer to **Headrest Drift Adjustment** on page 12.)

Positioning For Wheel Chair

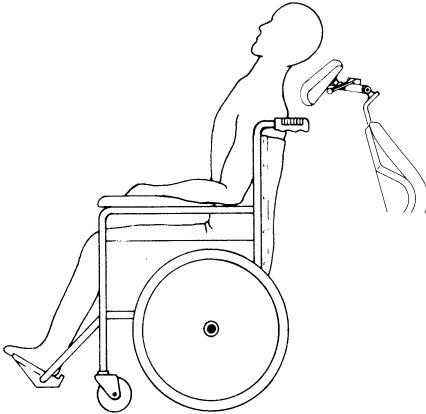

Figure 7. Positioning For Wheel Chair Usage

The headrest can be used to accommodate wheelchair patients. Slide the headrest up until it is free from the chair, turn it 180°, then slide it back into the backrest and push it all the way down. Run the chair to its full Back Up position. Adjust headrest height by moving the chair up or down (using the Base Up function on the foot-switch), then position the headrest as desired.

Headrest Drift Adjustment

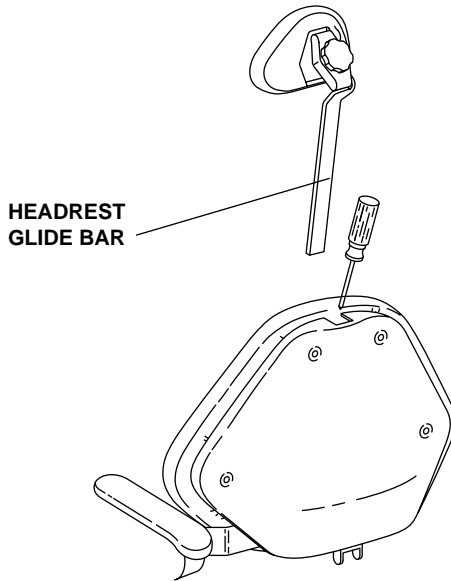

Figure 8. Headrest Drift Adjustment

Note

The back cover does not have to be removed to adjust glide bar tension.

If the headrest drifts downward, or if you find the headrest difficult to move up or down, the glide bar tension must be adjusted (*see Figure 8*). Remove the headrest glide bar to access the adjusting screw.

Using a Phillips screwdriver, adjust the glide bar tension. Turn the adjusting screw clockwise three to four revolutions to increase friction and hold the headrest more securely. Turn the screw counter-clockwise three to four revolutions to decrease friction and allow the headrest to move up and down more freely. Reinstall the headrest and recheck glide bar tension.

Left/Right Conversion

When combined with a conversion-compatible A-dec chair-mounted handpiece control system, your Decade 1011 chair allows you to convert for either left- or right-hand delivery. **If you have a Radius™ Delivery System**, go to page 15.

1. Lower the chair back, then disconnect the chair from the power source to prevent injury caused by accidental lowering of the chair. Lift the toeboard and secure the tilt roller assembly under the hook on the underside of the toeboard (see Figure 9). This will help support the toeboard. Place the armrests in their full down position.

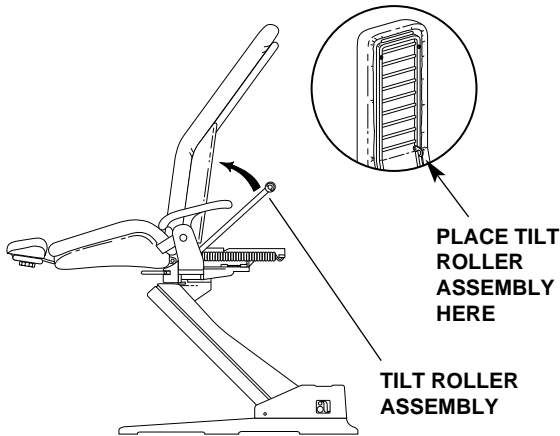

Figure 9. Left/Right Conversion Access

2. If the unit is equipped with a Self-contained Water System, move the Master On/Off Toggle to the OFF position. Use the syringe to bleed the system of air and water pressure, then remove the bottle. Position the control head over the post box and the assistant's arm in front of the chair.

3. Unscrew and remove the hex-head bolt from the chair adapter (see Figure 10). Pivot the chair adapter post and the post box to the other side of the chair. Align the hole in the chair casting with the hole in the adapter post.

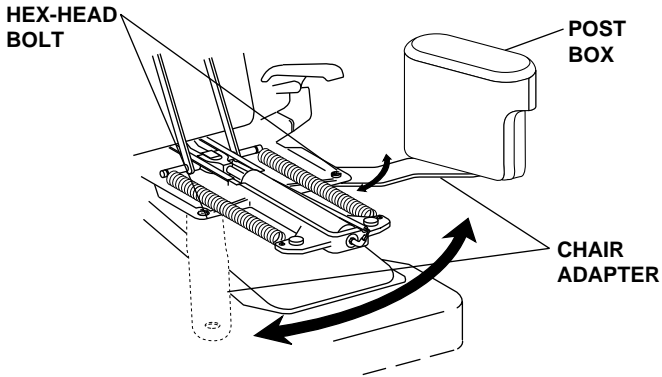

Figure 10. Left/Right Chair Mount Conversion

4. Reinstall the bolt in the chair adapter and tighten it firmly.
5. Position the post box:

Note

Avoid rotating the post box in a complete circle since doing so could twist the lines inside the floor box.

If you have a Decade Unit, remove the post box cover. Hold the post box to prevent it from falling. Use a 1/4-inch hex key to loosen the set screw located in the end of the post box nearest the post. Rotate the post box to the desired position. Then tighten the set screw and replace the post box cover.

If you have a Cascade® Delivery System, remove the post box covers. Use a 15/16-inch wrench to loosen the bolt located in the center of the post box frame. Rotate the post box to the desired position. Then tighten the bolt and replace the covers.

6. Replace the self-contained water system bottle. Lower the toeboard, return the chair to the entry position and move the foot control to the other side of the chair.

If you have a Radius® Delivery System, simply rotate the handpiece control and light arms to the desired position.

The Radius' unique bearing mount allows the delivery system to rotate around the toeboard in one continuous motion, eliminating the need for tools or fine adjustments.

Optional Duplex Outlet

A duplex outlet is available. It may be installed on the chair mount arm (depending upon your equipment) or on the chair frame. Contact your authorized A-dec dealer for details.

Care Instructions

For surface cleaning and disinfection instructions, refer to your *Equipment Asepsis Owner's Guide*, A-dec Publication No. 85-0696-00.

MAINTENANCE

Upholstery Replacement

A-dec's seamless upholstery makes replacement quick and easy. The upholstery on your Decade 1011 chair is installed in four sections: back, seat, headrest, and armrests. Each section is easily removed and replaced.

Backrest Upholstery

Remove the four screws securing the backrest cover and set the cover and screws aside. Using a 5/64-inch hex key, remove the four mounting screws that hold the upholstery to the backrest, then remove the existing upholstery. Reverse this procedure to replace the upholstery.

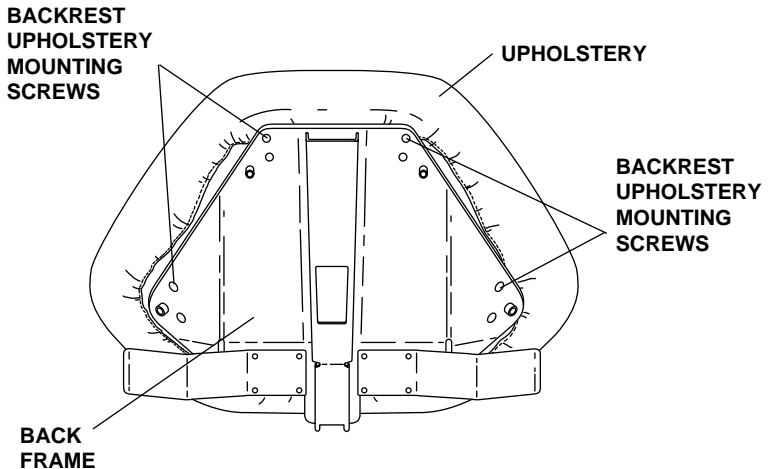

Figure 11. Backrest Upholstery

Seat/Toeboard Upholstery

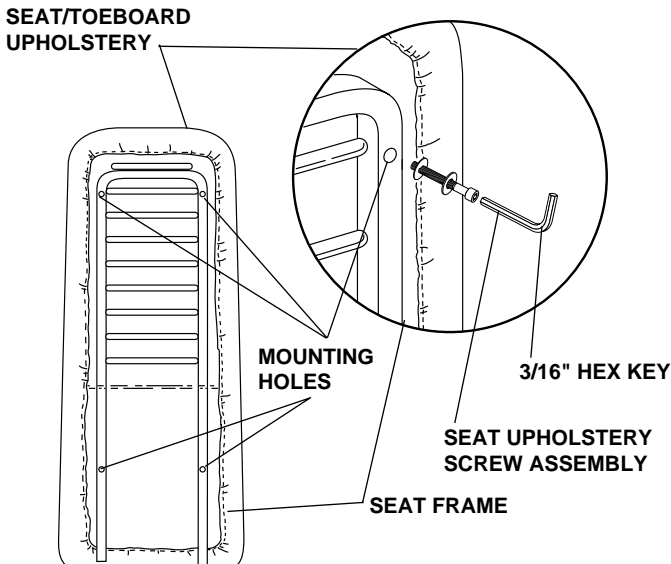

Figure 12. Replacing Seat/Toeboard Upholstery

1. Lower the back. Lift the toeboard while holding onto the frame and upholstery.
2. Remove the clear vinyl toeboard cover.
3. Remove the four seat upholstery screws that secure the seat/toeboard assembly to the seat frame.
4. Lower the toeboard and lift off the seat/toeboard upholstery assembly.
5. Place the new seat/toeboard upholstery assembly onto the frame assembly and raise the chair.
6. With the toeboard down, align the two mounting holes at the toeboard end of the seat/ toeboard upholstery assembly with the two mounting holes in the frame assembly.

7. Install two seat upholstery screws at the toeboard end, then raise the toeboard.
8. Install the remaining two seat upholstery screws and then lower the toeboard.
9. Attach the new clear vinyl toeboard cover.

Armrest Upholstery

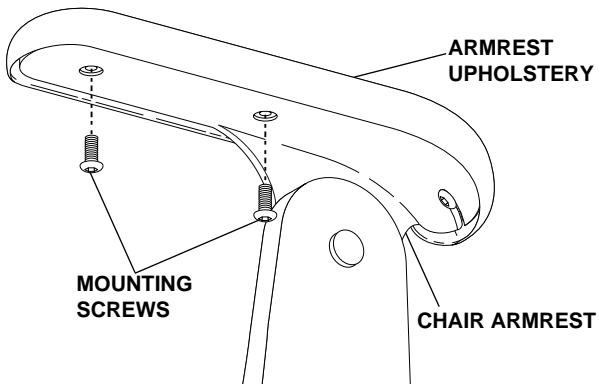

Figure 13. Replacing Armrest Upholstery

1. Using a 1/8-inch hex key, remove the mounting screws from the underside of each armrest.
2. Remove the armrest upholstery by sliding it off of the armrest.
3. Slide the new armrest upholstery onto the armrest.
4. Secure the armrest upholstery with the mounting screws.

Double Articulating Headrest Upholstery

Use the following procedure to replace the double articulating headrest upholstery.

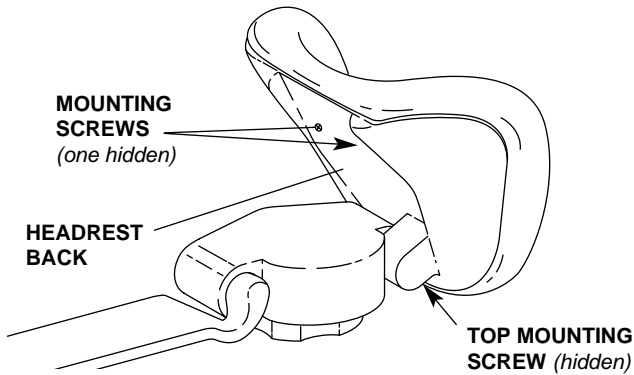

Figure 14. Replacing Headrest Upholstery

1. Loosen the headrest knob and rotate the headrest to a full upright position.
2. Remove the top Phillips mounting screw located just above the knob assembly.
3. Rotate the headrest back 45° to expose the two (2) Phillips mounting screws on the headrest back (see Figure 14). Remove the two (2) screws and the headrest cushion.
4. To attach the replacement upholstery, reverse this procedure. *DO NOT* tighten the screws until all three screws have been started.

To order a new upholstery set, contact your authorized A-dec dealer.

Service Information

Given proper care, your Decade 1011 Dental Chair will provide years of reliable service. In the event that something does go wrong with the chair, you should call your dealer. Any time you call your dealer, be prepared to provide the following information about your unit:

1. Model number.*
2. Serial number.*
3. Symptoms of the problem.
4. What action(s) you have taken toward correcting the problem.

* The model and serial number tag is located under the seat/toeboard, beside the spring. The first four digits on the tag are the model number (1011), the remaining digits are the chair serial number.



2601 Crestview Drive
Newberg, Oregon 97132 U.S.A.
Telephone 800-547-1883
(503) 538-7478
Fax (503) 538-0276

